

# S12.0 Step Feeder With Fastener Hopper



SKU: S120-101

## S12.0 Step Feeder With Fastener Hopper

An electrically motorized 12" (305mm) step feeder with a fastener hopper suitable for feeding or presenting fasteners to a drive head or dispenser assembly.

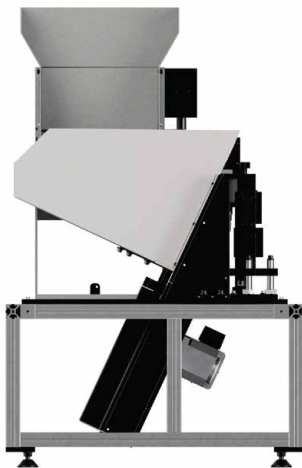

## Anatomy & Features

The S12.0 Series of step feeders comes complete with hardened tool steel and stainless steel escapement. Optic controls switch the bowl vibration on and off to prevent excessive wear and over-pressurization of escapement and tooling areas as seen on other manufacturer's systems.

Featuring an electrically motorized screw elevator assembly which lifts fasteners from the tray into the inline track, step feeders are a more silent option for feeding fasteners. The low vibration also helps to reduce the uneven coating distribution of fasteners coated with loctite or other substrates that is sometimes seen in vibratory bowl feeding.

The unique Carlson Fastener Hopper design sits snugly above the vibratory bowl, unlike competing manufacturer models that site adjacent to the device. This causes less footprint, leaving more valuable floor or table space available.

- ✓ Resistant to wear & tear damage
- ✓ Non-magnetic nickel-teflon coating
- ✓ Ideal method for silently feeding/presenting coated fasteners
- ✓ 3-Step fastener alignment verification prevents jams
- ✓ Hardened & heat-treated durable tool steel composition
- ✓ Longer run time between feeds due to less track level fastener jams
- ✓ Less pinch points & no mechanical adjustments for enhanced safety

## Product Technical Data

Step Size	12.0" (305mm)
Fastener Delivery Method	Blow Feed Delivery
Max. Fastener Head Ø	50mm
Max. Fastener Length	127mm
Max. Fastener Shaft Ø	20mm
Fastener Type	Screw, Set Screw, Nut, Bolt, Pin, Stud, Rivet